

0.5 mm-Pitch Slide-Lock FPC Connector

XF2L

Low-Profile SMT ZIF (Zero Insertion Force) Connectors' Small Footprint Reduces Space on Circuit Boards

- Low profile, measures just 1.2 mm max. above the board
- Top and bottom contact styles have identical dimensions, utilize the same PCB layout for board design efficiency
- Hold down terminal improves connection stability during soldering
- Slide mechanism locks securely
- Connectors supplied on tape reels for automatic insertion; color-coded reels facilitate identification
- Color-coded slide identifies top and bottom contact versions to prevent mix-ups during production

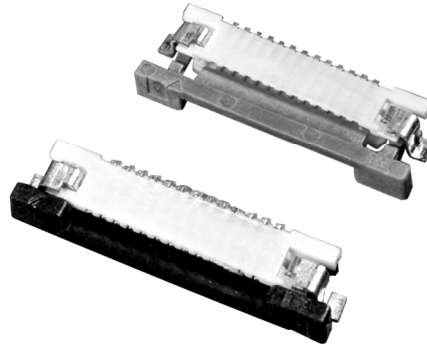

Ordering Information

Circuits	Contact location	Part number	Circuits	Contact location	Part number	Quantity per reel
4	Top contact	XF2L-0425-1	13	Top contact	XF2L-1325-1	3,000 per reel. Order in multiples of the quantity per reel.
5	Bottom contact	XF2L-0535-1		Bottom contact	XF2L-1335-1	
6	Top contact	XF2L-0625-1	15	Bottom contact	XF2L-1535-1	
7	Top contact	XF2L-0725-1	18	Bottom contact	XF2L-1835-1	
	Bottom contact	XF2L-0735-1	20	Bottom contact	XF2L-2035-1	
8	Top contact	XF2L-0825-1	21	Top contact	XF2L-2125-1	
	Bottom contact	XF2L-0835-1	22	Bottom contact	XF2L-2235-1	
10	Top contact	XF2L-1025-1	26	Top contact	XF2L-2625-1	
12	Bottom contact	XF2L-1235-1	30	Top contact	XF2L-3025-1	
				Bottom contact	XF2L-3035-1	

Note: Connectors with different circuit counts and contact locations are available on special order. Contact your Omron representative.

Specifications

Rated current	0.5 A
Rated voltage	50 VDC
Contact resistance	30 MΩ max. at 20 mVDC, 100 mA max.
Insulation resistance	100 MΩ min. at 250 VDC
Withstand voltage	250 VAC for 1 minute (with a leakage current of 1 mA max.)
Insertion tolerance	20 times
Ambient temperature	-30°C to 85°C (-22°F to 185°F); no condensation at low temperatures

MATERIALS/FINISH

Location	Top contact type	Bottom contact type
Housing	LCP resin (UL94V-0)/natural	LPC resin (UL94V-0)/natural
Slide lock	LCP resin (UL94V-0)/black	LCP resin (UL94V-0)/brown
Contact	Copper-alloy/nickel spring substrate (2 μm) plated with tin alloy (2 μm)	
Hold-down	Copper-alloy/hot-dip silver plated	

Dimensions

Unit: mm (inch)

XF2L-□□□□-1

Applicable FPC Dimensions

Printed Circuit Board Matching Dimensions (Top View)

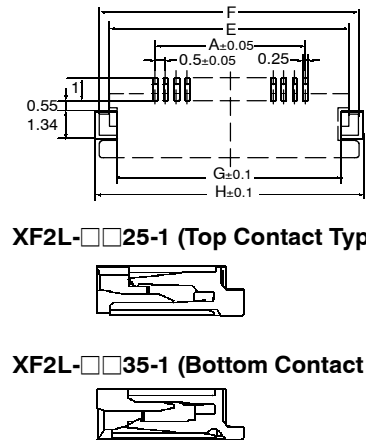
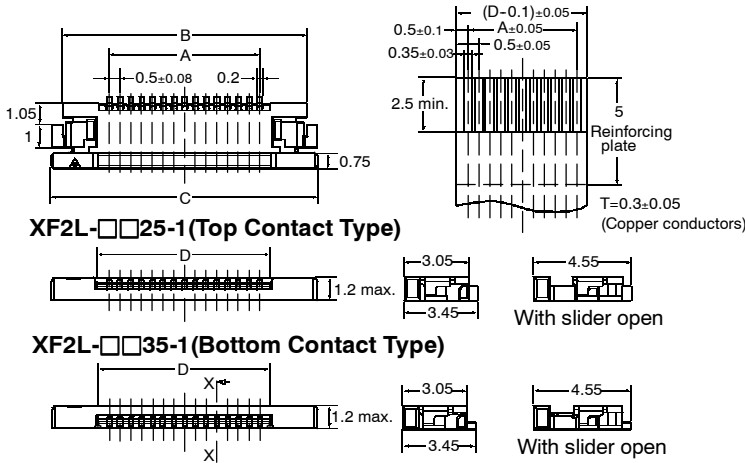

Top Contact Type

Circuits	Part number	A	B	C	D	E	F	G	H
4	XF2L-0425-1	1.5 (0.059)	5.9 (0.232)	6.9 (0.272)	2.6 (0.102)	5.88 (0.231)	6.88 (0.271)	5.28 (0.208)	7.28 (0.287)
6	XF2L-0625-1	2.5 (0.098)	6.9 (0.272)	7.9 (0.311)	3.6 (0.142)	6.88 (0.271)	7.88 (0.310)	6.28 (0.247)	8.28 (0.326)
7	XF2L-0725-1	3.0 (0.118)	7.4 (0.291)	8.4 (0.331)	4.1 (0.161)	7.38 (0.291)	8.38 (0.330)	6.78 (0.267)	8.78 (0.346)
8	XF2L-0825-1	3.5 (0.138)	7.9 (0.311)	8.9 (0.350)	4.6 (0.181)	7.88 (0.310)	8.88 (0.350)	7.28 (0.287)	9.28 (0.365)
10	XF2L-1025-1	4.5 (0.177)	8.9 (0.350)	9.9 (0.390)	5.6 (0.220)	8.88 (0.350)	9.88 (0.389)	8.28 (0.326)	10.28 (0.405)
13	XF2L-1325-1	6.0 (0.236)	10.4 (0.409)	11.4 (0.449)	7.1 (0.279)	10.38 (0.409)	11.38 (0.448)	9.78 (0.385)	11.78 (0.464)
21	XF2L-2125-1	10.0 (0.394)	14.4 (0.567)	15.4 (0.606)	11.1 (0.437)	14.38 (0.566)	15.38 (0.605)	13.78 (0.542)	15.78 (0.621)
26	XF2L-2625-1	12.5 (0.492)	16.9 (0.665)	17.9 (0.705)	13.6 (0.535)	16.88 (0.665)	17.88 (0.701)	16.28 (0.641)	18.28 (0.720)
30	XF2L-3025-1	14.5 (0.571)	18.9 (0.744)	19.9 (0.783)	15.6 (0.614)	18.88 (0.743)	19.88 (0.783)	18.28 (0.720)	20.28 (0.798)

Bottom Contact Type

Circuits	Part number	A	B	C	D	E	F	G	H
5	XF2L-0535-1	2.0 (0.079)	6.4 (0.252)	7.4 (0.291)	3.1 (0.122)	6.38 (0.251)	7.38 (0.290)	5.78 (0.227)	7.78 (0.306)
7	XF2L-0735-1	3.0 (0.118)	7.4 (0.291)	8.4 (0.331)	4.1 (0.161)	7.38 (0.290)	7.88 (0.310)	6.78 (0.267)	8.78 (0.346)
8	XF2L-0835-1	3.5 (0.138)	7.9 (0.311)	8.9 (0.350)	4.6 (0.181)	7.88 (0.310)	8.88 (0.330)	7.28 (0.287)	9.28 (0.365)
12	XF2L-1235-1	5.5 (0.216)	9.9 (0.390)	10.9 (0.394)	6.6 (0.310)	9.88 (0.389)	10.88 (0.428)	9.28 (0.365)	11.28 (0.444)
13	XF2L-1335-1	6.0 (0.236)	10.4 (0.409)	11.4 (0.449)	7.1 (0.279)	10.38 (0.409)	11.38 (0.448)	9.78 (0.385)	11.78 (0.464)
15	XF2L-1535-1	7.0 (0.276)	11.4 (0.449)	12.4 (0.488)	8.1 (0.319)	11.38 (0.448)	12.38 (0.487)	10.78 (0.424)	12.78 (0.503)
18	XF2L-1835-1	8.5 (0.335)	12.9 (0.508)	13.9 (0.547)	9.6 (0.378)	12.88 (0.507)	13.88 (0.546)	12.28 (0.507)	14.28 (0.562)
20	XF2L-2035-1	9.5 (0.374)	13.9 (0.547)	14.9 (0.596)	10.6 (0.417)	13.88 (0.546)	14.88 (0.586)	13.28 (0.523)	15.28 (0.602)
22	XF2L-2235-1	10.5 (0.413)	14.9 (0.596)	15.9 (0.626)	11.6 (0.457)	14.88 (0.586)	15.88 (0.625)	14.28 (0.562)	16.28 (0.641)
30	XF2L-3035-1	14.5 (0.51)	18.9 (0.744)	19.9 (0.783)	15.6 (0.614)	18.88 (0.745)	19.88 (0.783)	18.28 (0.720)	20.28 (0.798)

TAPE AND REEL DIMENSIONS

Unit: mm (inch)

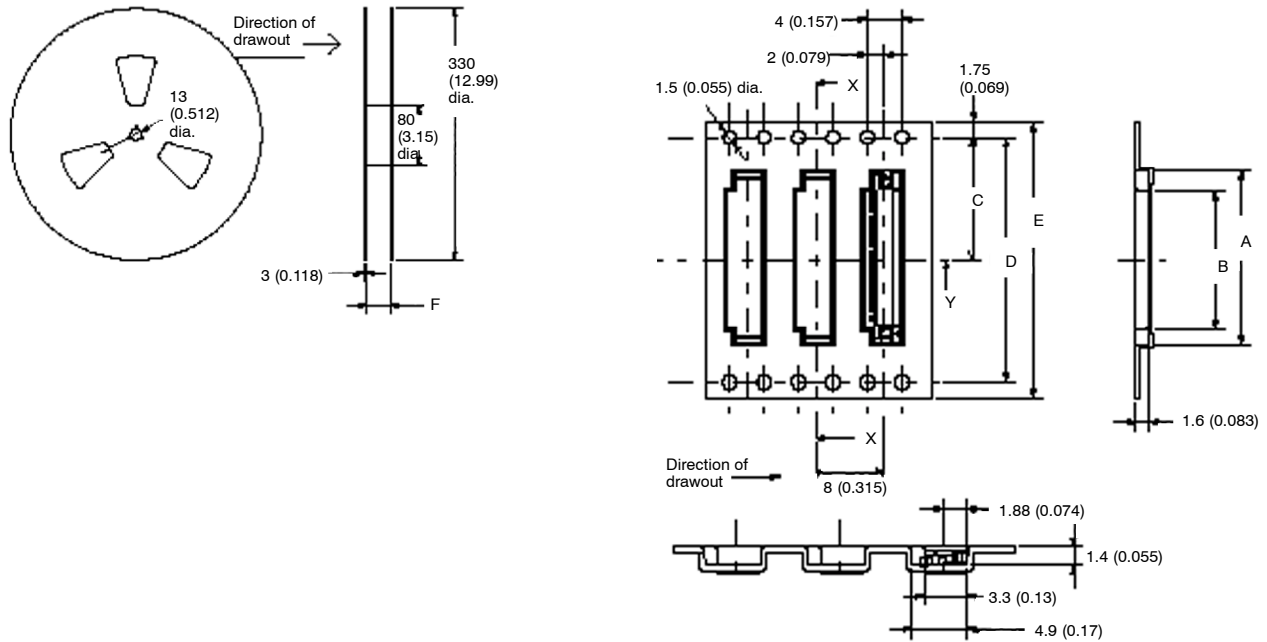

Top Contact Type

Circuits	Part number	A	B	C	D	E	F*
4	XF2L-0425-1	7.1 (0.280)	5.1 (0.201)	3.0 (0.118)	6.5 (0.256)	—	15.0 (0.591)
6	XF2L-0625-1	8.1 (0.319)	6.1 (0.240)	4.0 (0.157)	7.5 (0.295)	—	16.0 (0.630)
7	XF2L-0725-1	8.6 (0.339)	6.6 (0.260)	4.5 (0.177)	7.5 (0.295)	—	16.0 (0.630)
8	XF2L-0825-1	9.1 (0.358)	7.1 (0.280)	5.0 (0.197)	7.5 (0.295)	—	16.0 (0.630)
10	XF2L-1025-1	10.1 (0.398)	8.1 (0.319)	6.0 (0.236)	11.5 (0.453)	—	24.0 (0.945)
13	XF2L-1325-1	11.6 (0.457)	9.6 (0.378)	7.5 (0.295)	11.5 (0.453)	—	24.0 (0.945)
21	XF2L-2125-1	15.6 (0.614)	13.6 (0.585)	11.5 (.453)	11.5 (0.453)	—	24.0 (0.945)
26	XF2L-2625-1	18.1 (0.713)	16.1 (0.634)	14.0 (0.551)	14.2 (0.559)	28.4 (1.118)	32.0 (1.260)
30	XF2L-3025-1	20.1 (0.791)	18.1 (0.713)	16.0 (0.630)	14.2 (0.559)	28.4 (1.118)	32.0 (1.260)

Note: *For tape widths (dimension A) of 16 mm and 24 mm, pilot holes are located on one side only.

Bottom Contact Type

Circuits	Part number	A	B	C	D	E	F
5	XF2L-0535-1	7.6 (0.299)	3.5 (0.138)	7.5 (0.295)	—	16.0 (0.630)	16.4 (0.646)
7	XF2L-0735-1	8.6 (0.339)	4.5 (0.177)	7.5 (0.295)	—	16.0 (0.630)	16.4 (0.646)
8	XF2L-0835-1	9.1 (0.358)	5.0 (0.197)	7.5 (0.295)	—	16.0 (0.630)	16.4 (0.646)
12	XF2L-1235-1	11.1 (0.398)	7.0 (0.276)	11.5 (0.453)	—	24.0 (0.945)	24.4 (0.961)
13	XF2L-1335-1	11.6 (0.437)	7.5 (0.295)	11.5 (0.453)	—	24.0 (0.945)	24.4 (0.961)
15	XF2L-1535-1	12.6 (0.457)	8.5 (0.335)	11.5 (0.453)	—	24.0 (0.945)	24.4 (0.961)
18	XF2L-1835-1	14.1 (0.496)	10.0 (0.394)	11.5 (0.453)	—	24.0 (0.945)	24.4 (0.961)
20	XF2L-2035-1	15.1 (0.555)	11.0 (0.433)	11.5 (0.453)	—	24.0 (0.945)	24.4 (0.961)
22	XF2L-2235-1	16.1 (0.594)	12.0 (0.72)	11.5 (0.453)	—	24.0 (0.945)	24.4 (0.961)
30	XF2L-3035-1	20.1 (0.791)	16.0 (0.630)	14.2 (0.559)	28.4 (1.118)	32.0 (1.260)	32.4 (1.276)

Precautions

■ RECOMMENDED REFLOW CONDITIONS

Pre-heat

Temperature: 150±10°C

Time: 60 to 120 seconds

Soldering

Temperature: 200 to 240°C

Time: Not exceeding 30 seconds
(Not exceeding 10 seconds at 240°C
maximum temperature.)

■ STORAGE

Do not store under high humidity levels as this may cause deterioration of the insulation.

■ HANDLING THE FPC

Do not forcibly bend or pull an FPC which has been mounted and locked. This may cause discontinuities in the FPC.

NOTE: DIMENSIONS SHOWN ARE IN MILLIMETERS. To convert millimeters to inches divide by 25.4.

OMRON[®]

OMRON ELECTRONICS LLC

One East Commerce Drive
Schaumburg, IL 60173

1-800-55-OMRON

OMRON ON-LINE

Global - <http://www.omron.com>
USA - <http://www.omron.com/oei>
Canada - <http://www.omron.com/oci>

OMRON CANADA, INC.

885 Milner Avenue
Scarborough, Ontario M1B 5V8

416-286-6465